



# INSTALLATION INSTRUCTIONS



FORD F-150

PART NO. 19572

## BILL OF MATERIALS:

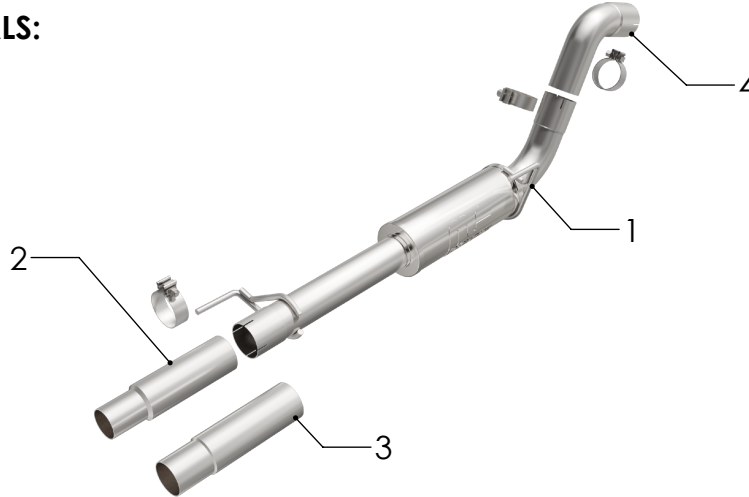

- 1. MUFFLER ASSEMBLY
- 2. INLET PIPE '15 - '20
- 3. INLET PIPE 2021
- 4. OUTLET PIPE 2021



WEAR SAFETY GLASSES



READ INSTRUCTIONS THOROUGHLY BEFORE INSTALLING PRODUCT



SPRAY LUBRICANT

To ease removal of existing exhaust components (especially on older vehicles) spray penetrating lubricant on all fasteners and hangers/insulators that will be loosened or removed and let soak before disassembly.

## HARDWARE KIT:

- 1. [2] 3.00" Band Clamp
- 2. [1] 3.18" Band Clamp

## MINIMUM REQUIRED TOOLS:



15mm



Saw (or Other Cutting Tool)



Hanger Tool (Or Pry Bar)

## MAGNAFLOW RECOMMENDS PROFESSIONAL INSTALLATION ON ALL THEIR PRODUCTS



**WARNING:** When working on, under, or around any vehicle exercise caution. Please allow the vehicle's exhaust system to cool before removal, as exhaust system temperatures may cause severe burns. If working without a lift always consult vehicle manual for correct lifting specifications. Always wear safety glasses and ensure a safe work area. Serious injury or death could occur if safety measures are not followed.

**ATTENTION:** Always install any supplied band or V-band clamps to the proper torque specifications of 40-45 ft-lbs for band clamps and 70 in-lbs for V-band clamps. Over tightening will result in the clamp breaking and will NOT be warranted by MagnaFlow.

MAGNAFLOW: 1901 Corporate Centre Dr - Oceanside, CA 92056 | 1(800)990-0905  
Technical Support: 1(800) 959-9226 | Email: moreinfo@magnaflow.com

## INSTALLATION INSTRUCTIONS

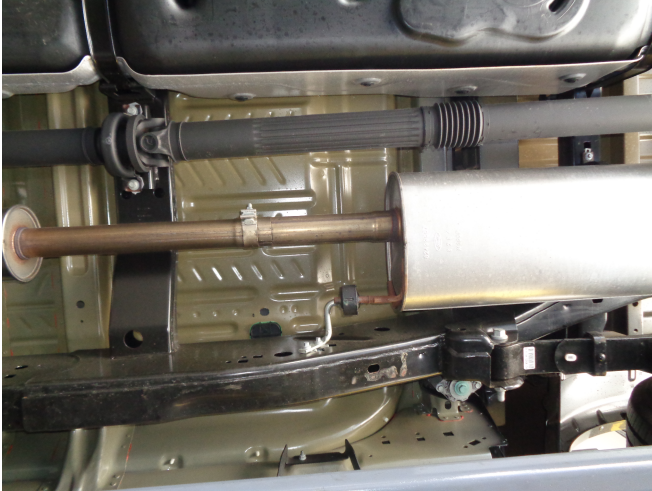

**Step 1.** For '15-'20 models begin removal of the OE muffler by marking cut point to the rear of OE Muffler as shown in photo below. Then cut the OE Exhaust at that cut point.

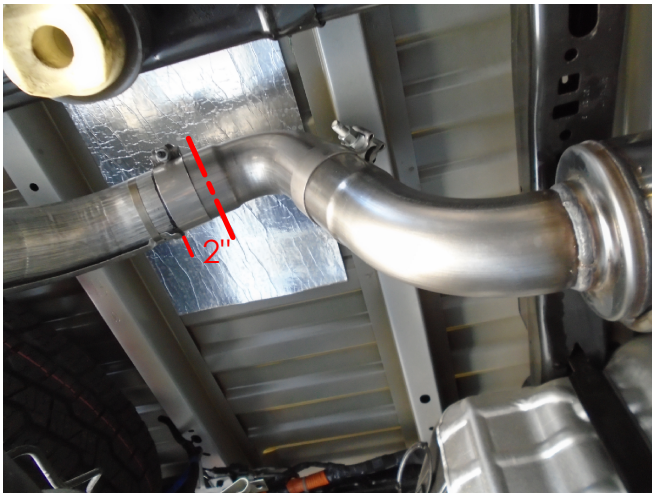

**Step 2.** For 2021 cut the 2" forward of the OE tail pipe heat shield.

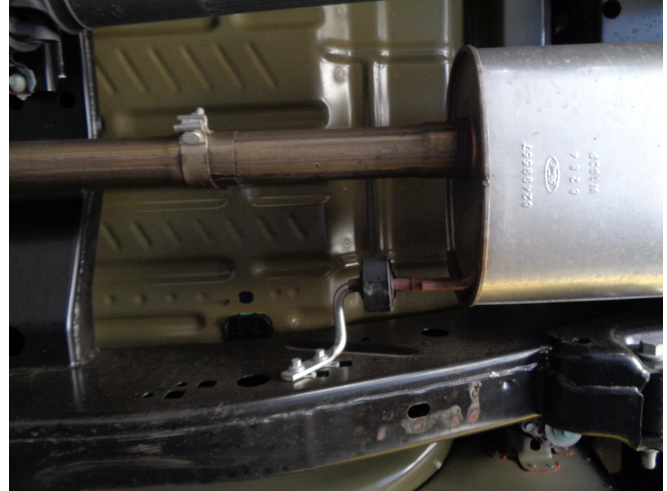

**Step 3:** Remove the mid section of the OE exhaust by loosening the clamp forward of the muffler shown. Then disengage the hangers from the rubber insulators. Be sure to not damage the rubber insulators as these will be used for the new MAGNAFLOW Muffler.

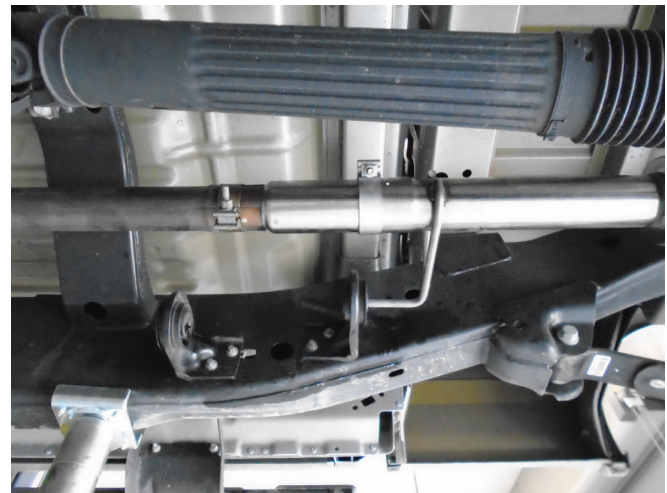

**Step 4:** Install Inlet Pipe for your application. The smaller inlet diameter is for 2015 - 2020, the larger is for 2021. Loosely attach the inlet of the Inlet Pipe to the vehicles inlet pipe outlet using the OE clamp.

**MAGNAFLOW:** 1901 Corporate Centre Dr - Oceanside, CA 92056 | 1(800)990-0905  
**Technical Support:** 1(800) 959-9226 | Email: [moreinfo@magnaflow.com](mailto:moreinfo@magnaflow.com)

## INSTALLATION INSTRUCTIONS

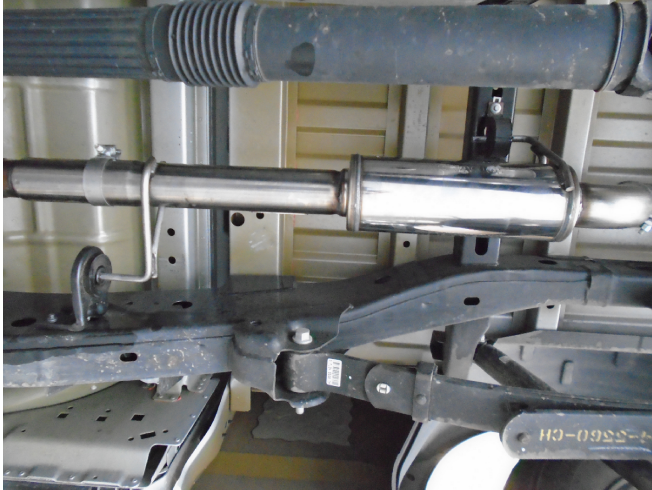

**Step 5:** Slip the Muffler Assembly inlet over the Inlet Pipe outlet. Loosely secure with the supplied clamp. Engage the welded hangers to the rubber insulators.



**Step 6:** For '15-'20 models slip the Muffler Assembly outlet to the cut OE muffler pipe. Loosely secure with the supplied clamp.

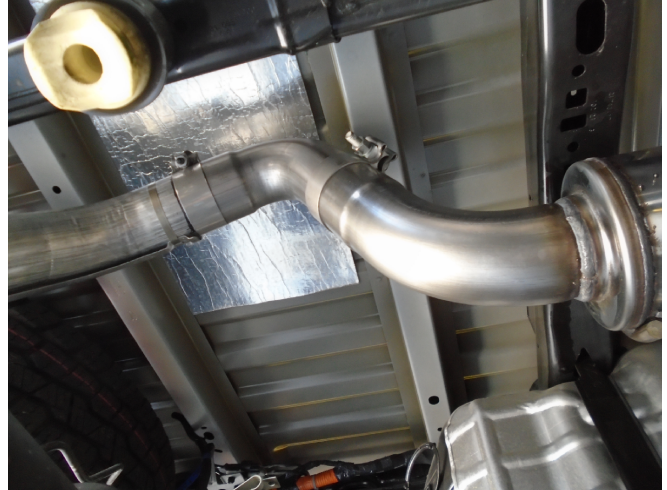

**Step 7:** For 2021 models slip the Muffler Assembly outlet to the supplied Outlet Pipe with the 3" clamp. Then attach the cut tail pipe using the 3.18" clamp. Loosely secure both clamps.



**Step 8:** Once a final position has been chosen for the new exhaust system, evenly tighten all clamps. Inspect after 25-50 miles for operation and re-tighten if necessary.

**MAGNAFLOW:** 1901 Corporate Centre Dr - Oceanside, CA 92056 | 1(800)990-0905  
**Technical Support:** 1(800) 959-9226 | Email: [moreinfo@magnaflow.com](mailto:moreinfo@magnaflow.com)